

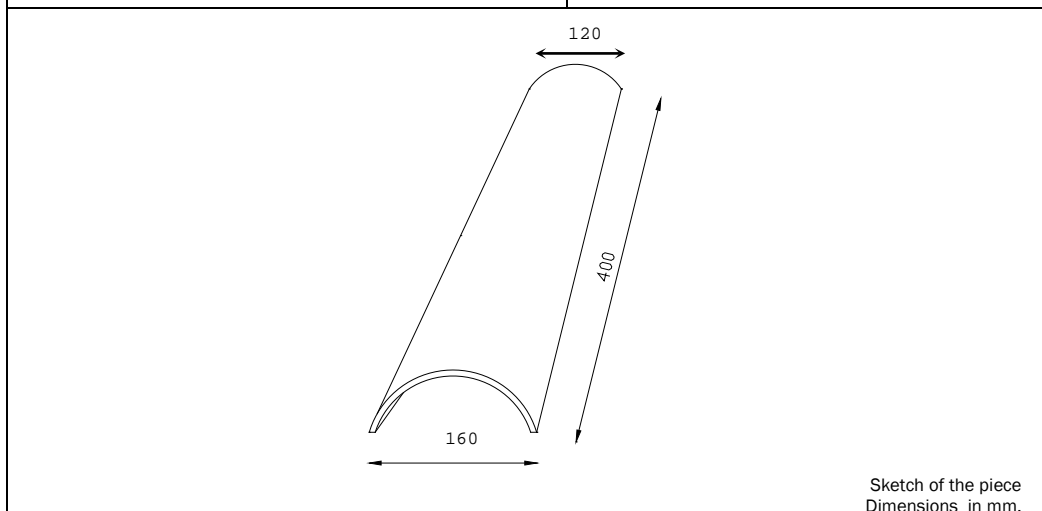

TECHNICAL SHEET FOR BAKED CLAY ROOFING TILES AND AUXILIARY EQUIPMENT

Signature and stamp

INFORMATION OF THE MANUFACTURER	INFORMATION OF THE PRODUCTION CENTRE	
MANUFACTURER: TEJAS PÉREZ GARCÍA, S.A.	MANUFACTURER: TEJAS PÉREZ GARCÍA, S.A.	
ADRESS: Camino del Pozuelo, S/N	ADRESS: Camino del Pozuelo, S/N	
PO Box / Location: 23710 / Bailén (Jaén)	PO Box / Location: 23710 / Bailén (Jaén)	



Vº Bº
TEJAS PÉREZ GARCÍA, S.A.

TYPE OF THE PRODUCT	Baked Clay Curved Roof Tile Red 400 x 160 x 120 mm.
COMERCIAL NAME	RED ROOF TILE 40 x 16

TECHNICAL INFORMATION

Characteristic	Checking method	Performance Guaranteed by Tejas Pérez García, S.A.	Harmonised Technical Specifications (UNE-EN 1304)
STRUCTURE CHARACTERISTICS (% DEFECTS)	UNE-EN 1304	≤ 2,5 %	≤ 2,5 %
NOMINAL DIMENSIONS	UNE-EN 1024	Length	400 mm.
		Max. Width	160 mm.
		Min. Width	120 mm.
		Length Tolerance	± 2,0 %
EVENNESS OF TRANSVERSE PROFILES	UNE-EN 1024	≤ 15 mm.	≤ 15 mm.
STRAIGHTNESS / WARPING	UNE-EN 1024	L > 300 mm.	≤ 1,0 %
		L ≤ 300 mm.	-
WATERPROOF QUALITIES (Method 1)	UNE-EN 539-1	Classification	Category 1
		Middle value	≤ 0,1 cm³/cm²/day
		Individual value	≤ 0,2 cm³/cm²/day
FLEXURAL STRENGTH	UNE-EN 538	≥ 2000 N	≥ 1000 N
FROSTING RESISTANCE	UNE-EN 539-2 (Method E)	Classification	Level 2
		Nº of cycles exceeded	≥ 90 cycles
REACTION TO FIRE	UNE-EN 13501-1	Class A1	
BEHAVIOUR TO FIRE	UNE-EN 13501-5	B _{roof}	

SPECIAL PIECES:

COMMENTS: Roof installation according to UNE 136020

Data information from the construction work we have provided the material to, which has the photocopied technical information included here: The current document should be signed and stamped by the manufacturer to obtain a final qualification of the construction work: